



Standard

Protection of EHV Busbars

R246414

Version 5.0, June 2020

Authorisations

Action	Name and title	Date
Prepared by	Anthony Januba, Senior Asset Strategy Engineer	01/05/2020
Reviewed by	Stewart Collins, Senior Asset Strategy Engineer	20/05/2020
	Satendra Bhola, Principal Engineer Secondary Asset Engineering	20/05/2020
Authorised by	David Ellis, Substations Asset Strategy Team Leader	01/06/2020
Review cycle	30 months	

Responsibilities

This document is the responsibility of the Substations Asset Strategy Team, Tasmanian Networks Pty Ltd, ABN 24 167 357 299 (hereafter referred to as "TasNetworks").

Please contact the Substations Asset Strategy Team Leader with any queries or suggestions.

- Implementation All TasNetworks staff and contractors.
- Compliance All group managers.

Minimum Requirements

The requirements set out in TasNetworks' documents are minimum requirements that must be complied with by all TasNetworks team members, contractors, and other consultants.

The end user is expected to implement any practices which may not be stated but which can be reasonably regarded as good practices relevant to the objective of this document.

© Tasmanian Networks Pty Ltd 2014

Record of revisions

Section number	Details
Title	Changed from Protection of EHV Busbars Standard to Protection of EHV Busbars and Bus Couplers Standard
1.7	Added reference to cyber security standards
2.1 (h)	Modified end fault design policy
2.1 (i)	Added CB time of 60ms
2.1 (t)	Added reference to the new IEC 61850 standard
4	Added some cyber specific requirements
4.6 (a)	Added reference to the new IEC 61850 standard
5.1 (a)	Added reference to the new IEC 61850 standard
6	Added reference to the new IEC 61850 standard
7.6	Added more detail for end fault protection
Appendix 1	Note for equipment variation for IEC 61850

Table of contents

Authorisations.....	2
Responsibilities	2
Minimum Requirements	2
List of figures.....	5
Appendix.....	5
General	6
1.1 Purpose	6
1.2 Scope	6
1.3 Objective	6
1.4 Precedence	6
1.5 Abbreviations	7
1.6 Symbols	7
1.7 References	8
2 Policy	8
2.1 Design policy	8
3 Busbar protection functional requirements	9
3.1 Low impedance busbar protection	9
3.2 High impedance busbar protection.....	10
4 Protection application	11
4.1 LIBP application	11
4.2 HIBP application	12
4.3 Selectable busbar configuration.....	12
4.4 Ring bus configuration	13
4.5 Double breaker configuration	14
4.6 Circuit breaker and a half configuration.....	15
4.7 H-type configuration	16
5 Protection associated with EHV bus coupler	18
5.1 Design principles	18
5.2 Bus coupler protection functional requirements.....	19
6 Busbar protection settings.....	19
6.1 Setting requirements for busbar differential protection.....	19
6.1.1 General information.....	19

6.1.2	Setting requirement	20
6.2	LIBP settings	20
6.3	HIBP settings	20
7	Circuit breaker failure (CBF) protection	21
7.1	Design principles	21
7.2	CBF protection application	21
7.3	CBF protection settings	22
7.4	Differential current supervision	22
7.5	CT circuit supervision	22
7.6	End Fault or 'blind zone' protection	22

List of figures

Figure 1	Busbar protections for selectable busbar configuration	13
Figure 2	Busbar protections for ring bus configuration	14
Figure 3	Busbar protections for double breaker configuration	15
Figure 4	Busbar protections for circuit breaker and a half configuration	16
Figure 5	Busbar protections for H-type configuration with transmission line CBs.....	17
Figure 6	Busbar protections for H-type configuration with transformer CBs	18

Appendix

Appendix 1	Standard secondary equipment	23
------------	------------------------------	----

General

1.1 Purpose

The purpose of this document is to define the requirements, philosophy and the application of protection schemes for Extra High Voltage (EHV) busbars in the Tasmanian Interconnected Power System under the responsibility of TasNetworks.

1.2 Scope

The document applies to the protection schemes on EHV busbars under the responsibility of TasNetworks and applies to the following busbar configurations:

- (a) Single busbar.
- (b) Double or triple busbar with or without a transfer busbar.
- (c) Double breaker in the diameter between two main busbars.
- (d) Circuit breaker and a half in the diameter between two main busbars.
- (e) Ring busbar.
- (f) H-type busbar.
- (g) Or a combination of the above busbar arrangements.

This standard contains requirements for design and is to be applied at new installations as well as redevelopment of existing busbar protection schemes.

1.3 Objective

TasNetworks requires design as covered in this standard to ensure:

- (a) personnel and public safety;
- (b) safety of TasNetworks' assets;
- (c) reliability and continuity of power supply to the power transmission network;
- (d) that relevant Australian legal requirements are met;
- (e) that the requirements of the National Electricity Rules (NER) are met;
- (f) ease in operation and maintenance;
- (g) minimum disruption to the EHV supply system following a fault;
- (h) that the requirements of TasNetworks' corporate plan are met;
- (i) that the exposure of TasNetworks' business to risk is minimised; and
- (j) that TasNetworks' responsibilities under connection agreements are met.

1.4 Precedence

Any apparent conflict between the requirements of this standard and the law, mandatory requirements, industry standards, project specifications, non-statutory standards or guidelines, and any other associated documents should be brought to the immediate attention of TasNetworks for resolution and no action must be taken that might result in a breach of law or mandatory standard.

Where there may be a conflict between the requirements of this standard and any:

- (a) law, mandatory requirement or industry standard, then that law or statutory requirements will prevail over this standard;
- (b) non-mandatory standard, or guideline, then this standard will prevail over that standard or guideline; or
- (c) project specification, then a deviation must be specifically requested and approved in writing by TasNetworks' Substations Asset Strategy Team Leader.

Approval for a deviation to this standard may only be accorded if it does not reduce the quality of workmanship, pose a safety risk to personnel or equipment and does not deviate from the intent of this standard.

1.5 Abbreviations

CB	Circuit Breaker
CBF	Circuit Breaker Failure
CT	Current Transformer
EHV	Extra High Voltage (≥ 66 kV)
HIBP	High Impedance Busbar Protection
HMI	Human Machine Interface
IRIG B	Inter-Range Instrumentation Group type B (time code standard)
LIBP	Low Impedance Busbar Protection
NER	National Electricity Rules
NOCS	Network Operational Control System
PTP	Precision Time Protocol
SOE	Sequence of Events
SPAR	Single Pole Auto Reclose
SCADA	Supervisory Control and Data Acquisition
VT	Voltage Transformer

1.6 Symbols

R_1	Positive Sequence Resistance
X_1	Positive Sequence Reactance
Z_1	Positive Sequence Impedance
R_0	Zero Sequence Resistance
X_0	Zero Sequence Reactance
Z_0	Zero Sequence Impedance
ms	milliseconds
p.u.	per unit

1.7 References

As a component of the complete specification for a system, this standard is to be read in conjunction with other TasNetworks standards and documents as applicable. In particular, this includes the project specifications and the literature mentioned below.

- HV and LV Cable Systems Standard (R590630)
- Secondary Equipment Testing Standard (R244782)
- Protection and Control of Network Transformers Standard (R246242)
- Protection and Control of Supply Transformers Standard (R245707)
- Protection of Transmission Lines Standard (R246427)
- EHV Current Transformer Standard (R522690)
- EHV Voltage Transformer Standard (R586391)
- Extra High Voltage System Standard (R586386)
- General Substation Requirements Standard (R522687)
- DC Distribution System Standard (R522693)
- SCADA Systems Standard (R246439)
- IEC 61850 Protection and Automation Standard (R1606300)
- Substation Lightning Protection and Earthing Standard (R522692)
- Testing, Commissioning and Training Standard (R246497)
- Technology Asset and Change Management Standard (R1400111)
- Security Event Logging and Monitoring Standard (R1313426)

2 Policy

2.1 Design policy

The following design principles must be implemented:

- (a) The EHV busbar shall be protected by a single busbar protection scheme. However, as specified in clause S5.1.9 (e) of the NER, a duplicate busbar protection scheme shall also be applied where system studies demonstrate that, during a failure of a single busbar protection scheme, the fault clearance time by backup protection is greater than the critical clearance time for faults on any part of the EHV busbar.
- (b) Low impedance busbar protection (LIBP) shall be used where the circuits are capable of being connected to more than one busbar or if the current transformer (CT) is required to be shared with other protection relays.
- (c) High impedance busbar protection (HIBP) shall be used where the circuits cannot be switched from one busbar to another busbar. However, where IEC 61850 process bus is utilised, HIBP CT configuration is not required.
- (d) At substations with more than one busbar, the busbar protection shall be capable of discrimination between the busbars to ensure that the minimum numbers of circuit breaker (CB) are tripped to clear the bus fault.

- (e) A unit busbar protection scheme operating on current differential principles shall be provided for each of the EHV busbars.
- (f) The protection scheme applied is adaptable for various circuit configurations and adequate for the protection of the entire busbar.
- (g) The protection scheme is arranged to ensure no part of the busbar is unprotected.
- (h) The protection scheme is arranged to ensure that faults occurring in the protection 'blind zones' i.e. between the CT and the associated CB, shall be cleared by the operation of the circuit breaker failure (CBF) or End Fault protection and should trip fault infeed from the remote end.
- (i) The protection schemes are capable of independently tripping the CBs so as to clear the fault within specified fault clearance times as stated in the table S5.1a.2 of chapter 5 of the NER with an assumption that the CB will take upto 60 ms to clear the fault.
- (j) Where a dedicated busbar protection scheme is not warranted, the busbars shall be protected by using overlapping zones of the circuit protection, e.g. transmission line protection or transformer protection.
- (k) The busbar protection can have auxiliary tripping relays to trip all circuits. Such auxiliary relays if used, must provide high speed operation to ensure fault clearance times comply with NER requirements. The auxiliary relay shall have sufficient spare contacts to cater for the final proposed development of the substation plus a margin of 10 per cent.
- (l) Where possible, one busbar protection scheme shall have integrated CBF protection. The CBF protection shall use the disconnector image of the busbar protection for tripping purposes.
- (m) The secondary circuit of the CT should not be switched by disconnector auxiliary contacts for busbar imaging.
- (n) For 220 kV transmission lines, the CBF current check must be phase segregated to cater for single pole auto reclose (SPAR).
- (o) Busbar protection trip contacts must be latching type with the facility to reset locally from the front panel of the relay.
- (p) The facility to block the busbar protection and the CBF protection must be provided locally.
- (q) For duplicated schemes, the relays must be from different manufacturers or be based on different operating principles to achieve redundancy and diversity.
- (r) The busbar protection shall initiate CB tripping such that the 'A' busbar protection scheme trips the 'A' trip coil only and the 'B' busbar protection scheme trips the 'B' trip coil only of the connected CBs. In the case of a single busbar protection scheme, the busbar protection scheme shall trip both 'A' and 'B' trip coils of the respective CBs.
- (s) The busbar protection shall trip both the EHV and HV CBs of a connected transformer.
- (t) At sites where IEC 61850 process and/or station bus is implemented, all design requirements shall be in accordance with the TasNetworks IEC 61850 Protection and Automation Standard.

3 Busbar protection functional requirements

3.1 Low impedance busbar protection

The LIBP scheme shall be a numerical protection scheme providing the following functionality:

- (a) Capability to detect all fault types on the EHV busbar.
- (b) Provide protection for all types of phase and ground faults within its zone.

- (c) Be a unit protection system operating on the biased current differential principle with configurable slope characteristics.
- (d) Must comprise of busbar specific zones and an overall check zone, both of which must operate to initiate a trip.
- (e) Provide phase segregated measurement and phase identification for the faulted phase.
- (f) Be capable of providing up to four main bus protection zones excluding the overall check zone.
- (g) Be insensitive to harmonic and DC components in the fault current.
- (h) Be stable for faults external to the bus zone.
- (i) Have stability against CT saturation on through faults.
- (j) Include integrated CBF protection that uses the disconnector image to trip the relevant CBs (must be phase segregated in case of 220 kV). Where a separate CBF scheme is supplied, the disconnector image shall be used by the separate CBF protection.
- (k) Have at least 10 per cent spare capacity for digital inputs and outputs above those required for the engineered solution.
- (l) Have separate or configurable inputs for 1 and 5 Amp CTs and be able to continuously carry at least two times the relays rated current.
- (m) Be able to freely configure the CT ratio to represent the primary values in the circuit.
- (n) Be capable of communicating all parameters including alarms and controls to the substation SCADA system and be capable of being configured remotely.
- (o) Be configurable for an installation consisting of a number of different circuit arrangements e.g. multi-busbar selectable, double breaker and circuit breaker and one half configurations.
- (p) Have a local HMI to read primary data, to establish and read setting parameters and to access self-diagnosis details.
- (q) Provide self-supervision of measuring and peripheral relays.
- (r) Have facilities for IRIG B or PTP time synchronisation.
- (s) Be able to communicate to the SCADA system via DNP3.0 and IEC 61850 (GOOSE and MMS).
- (t) Provide SOE and oscillographic disturbance recording facilities capable of remote interrogation.
- (u) Have sufficient heavy duty contacts for direct tripping of CBs.
- (v) Be capable of CT secondary circuit supervision.
- (w) Be capable of communicating on the SCADA network via Ethernet RJ45 or fibre connection..

3.2 High impedance busbar protection

The HIBP scheme shall preferably be of numerical type protection with the following functionality:

- (a) Capability to detect all fault types on the EHV busbar.
- (b) Provide protection for all types of phase and ground faults within its zone.
- (c) Be based on phase segregated measurement and phase identification for the faulted phase.
- (d) Operate on the high impedance circulating current differential principle and is not required to have a check zone facility.
- (e) Be responsive only to 50 Hz fundamental components in the fault current.
- (f) Be stable for faults external to the busbar protection zone with CT saturation.

- (g) Be able to continuously carry at least two times the relays rated current.
- (h) Capable of supervision of current inputs to detect faulty CT secondary circuits.
- (i) Be capable of communicating all parameters including alarms and controls to the substation SCADA system and be capable of being configured remotely.
- (j) Have a local HMI to read primary data, to establish and read setting parameters and to access self-diagnosis details.
- (k) Provide self-supervision of protection relays.
- (l) Have facilities for IRIG B or PTP time synchronisation.
- (m) Be able to communicate to the SCADA system via DNP3.0 and IEC 61850 (GOOSE and MMS).
- (n) Provide SOE and oscillographic disturbance recording facilities capable of remote interrogation.
- (o) Preferably have sufficient heavy duty contacts for direct tripping of CBs.
- (p) Be capable of communicating on the SCADA network via Ethernet RJ45 or fibre connection.

4 Protection application

The busbar protection scheme shall have inherent flexibility to provide adequate protection for various busbar arrangements as listed in section 1.2. The application of busbar protection to particular EHV busbar configurations is covered in sections 4.3 through 4.7.

A LIBP scheme should be applied where a switch yard consists of both switchable and non-switchable circuits.

In order to mitigate any cyber risks, the following software controls and monitoring are to be implemented:

- (a) Change the device default password;
- (b) Disable or remove unused interfaces; and
- (c) Disable built-in or default user accounts.
- (d) If possible, record:
 - (i) What activity was performed (e.g. setting changes on protection relay);
 - (ii) Who performed the activity (e.g. engineer or operator); and
 - (iii) When the activity was performed (e.g. time and date).

4.1 LIBP application

The following design principles shall be followed for application of LIBP schemes:

- (a) Each LIBP scheme shall be connected to a separate CT core. Performance designation of the connected CT core shall match or exceed the CT requirement as stated by the manufacturer of the busbar protection scheme.
- (b) The scheme shall employ overlapping CTs for bus coupler applications where possible.
- (c) Where LIBP is based on central and standalone peripheral units, the peripheral units of all circuits should be housed in a centralised panel(s).
- (d) Where duplicate schemes are installed, the schemes must be connected to separate DC supplies.
- (e) The scheme shall utilise double point auxiliary contacts for a true representation of disconnecting.

4.2 HIBP application

The following design principles shall be followed for application of HIBP schemes:

- (a) Each HIBP scheme shall be connected to separate CT cores.
- (b) All CTs associated with the HIBP protection shall have the same ratio and performance designation and must not be shared with other devices or system.
- (c) The scheme shall employ overlapping CTs for bus coupler applications.
- (d) Where a HIBP scheme is applied, a separate CBF protection scheme shall be provided.
- (e) Where duplicate schemes are installed the schemes must be connected to separate DC supplies.

4.3 Selectable busbar configuration

The following protection design principles apply to selectable busbar configurations:

- (a) Figure 1 shows the LIBP scheme 'A' applied to a double bus configuration where transmission lines can be transferred to either busbar via a bus transfer disconnector. Within the 'A' busbar protection, two bus zones shall be provided and an overall check zone; one for circuits connected to Bus 'A', one for circuits connected to Bus 'B' and one for the entire switchyard. The duplicate 'B' protection shall be similarly arranged.
- (b) It is noted that both protection zones are connected together temporarily during switching operations when both bus disconnectors and the associated bus transfer disconnector are closed. The busbar protection scheme must be capable of recognising this condition with the same sensitivity and initiate the isolation of a fault by tripping all interconnected zones.
- (c) In the case of a fault within the overlapping zone within the bus coupler circuit, the main busses could be cleared sequentially, if directed by TasNetworks and providing the total fault clearance time is within 120 ms as stipulated in the NER.
- (d) Depending on auxiliary contact availability, it is preferred that auxiliary contacts of the disconnectors are used for imaging purposes.
- (e) Where only one busbar protection is specified in the project specification, a non-directional impedance based relay shall be applied to a bus coupler CT and an associated busbar VT. The function of this protection is to trip the bus coupler circuit breaker thus removing some current infeed to an uncleared bus fault allowing the extended reach from the remote back-up distance protection schemes.
- (f) As it is not possible to operate substations in the 'straight through' mode where a bus transfer disconnector is closed and both of the associated bus disconnectors are open, therefore a busbar protection zone for the 'straight through' connection shall not be provided.

Figure 1 Busbar protections for selectable busbar configuration

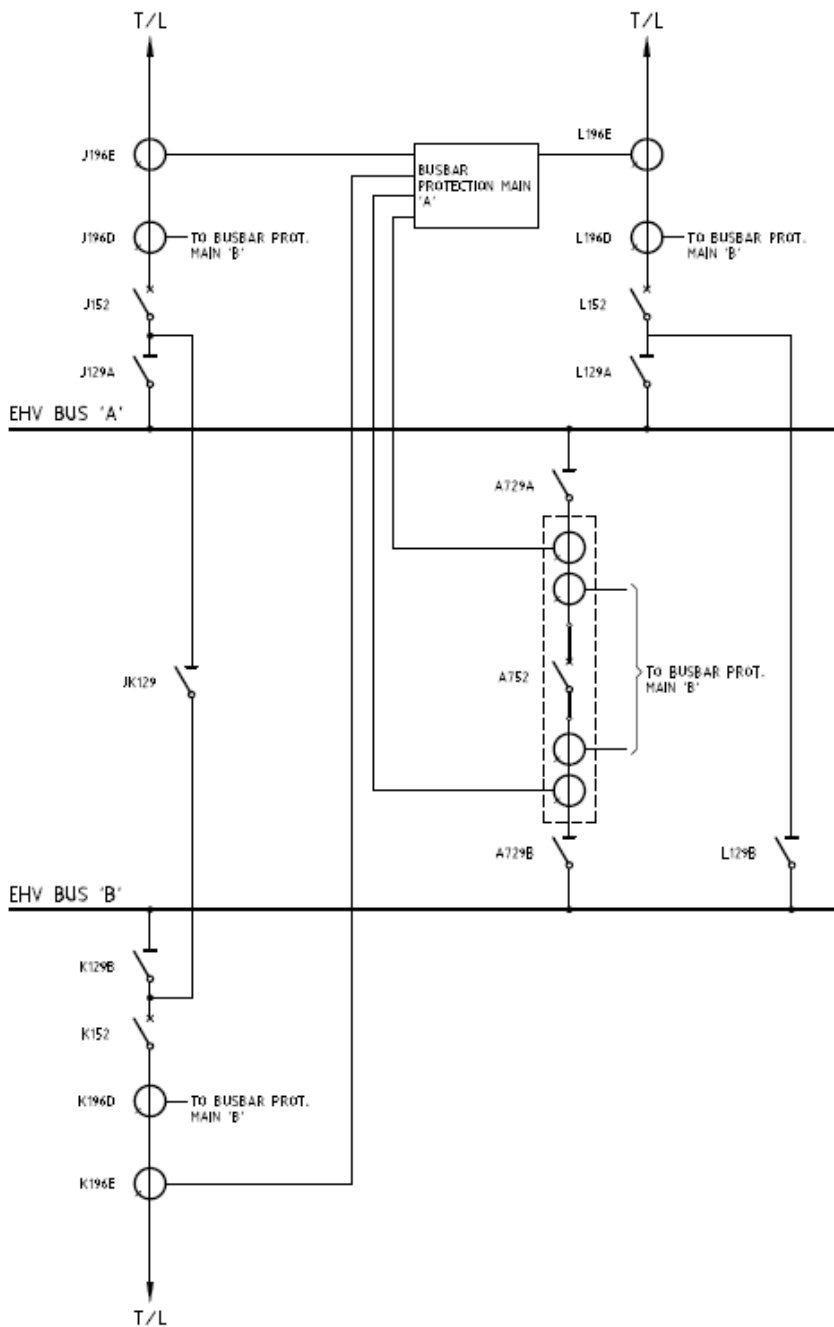

4.4 Ring bus configuration

Figure 2 shows the busbar protection provided by transmission line protection scheme connected to a Ring Bus configuration. The busbar protection for each section shall overlap each bus section CB. However; where a transmission line CB is also installed, separate busbar protection having protection zones overlapping the transmission line CB and the two bus section CBs shall be applied.

Figure 2 Busbar protections for ring bus configuration

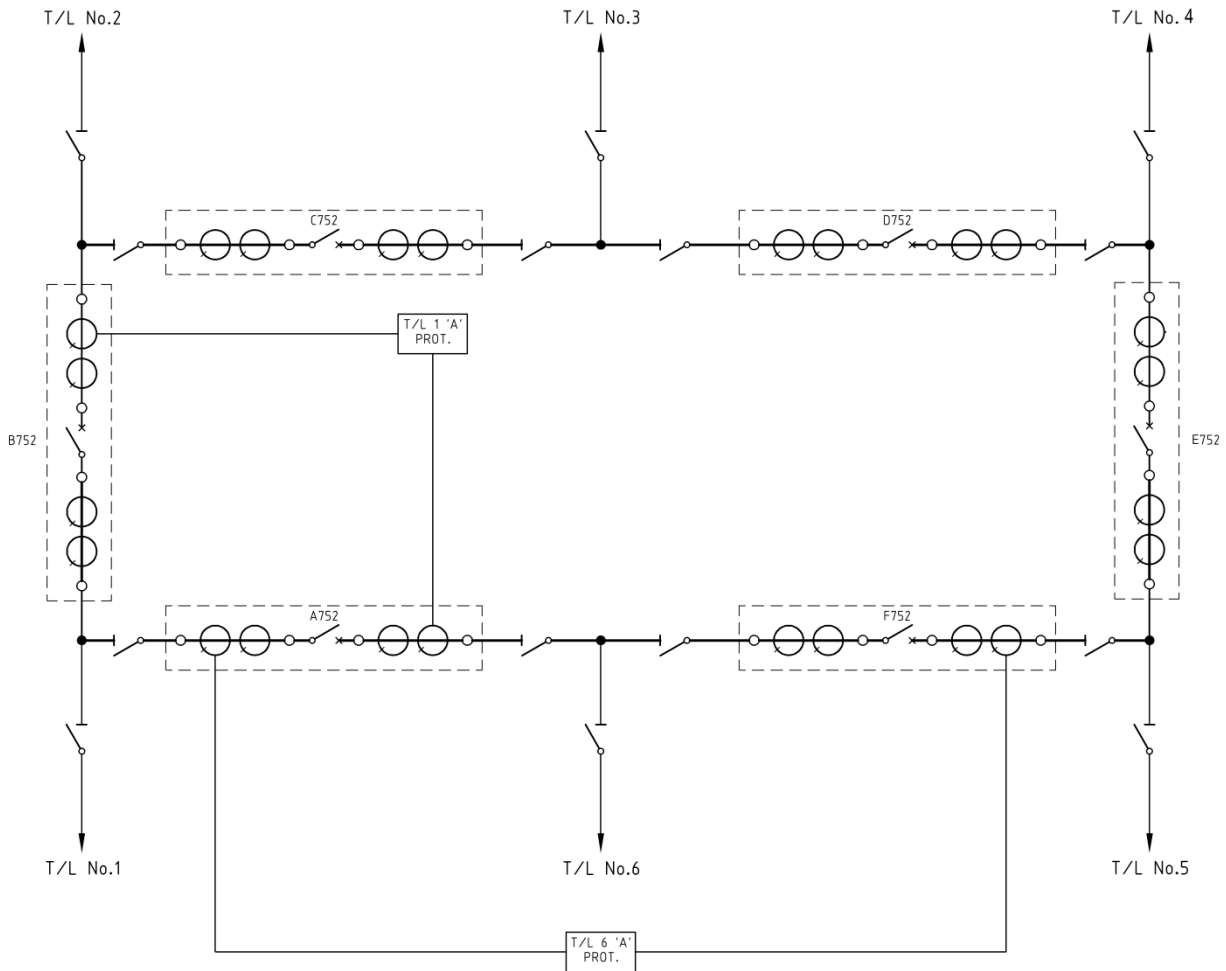

4.5 Double breaker configuration

Figure 3 shows a typical double breaker arrangement. The following recommendations apply to double breaker busbar configurations:

- (a) HIBP without a check feature may be applied to the 'A' and 'B' busbar protection schemes for each busbar.
- (b) The section of bus between the two CBs shall be protected by the transmission line duplicate protection scheme or the duplicate differential protection applied to the transformer. A dedicated busbar protection scheme is not warranted unless a line CB and associated CT are provided.

Figure 3 Busbar protections for double breaker configuration

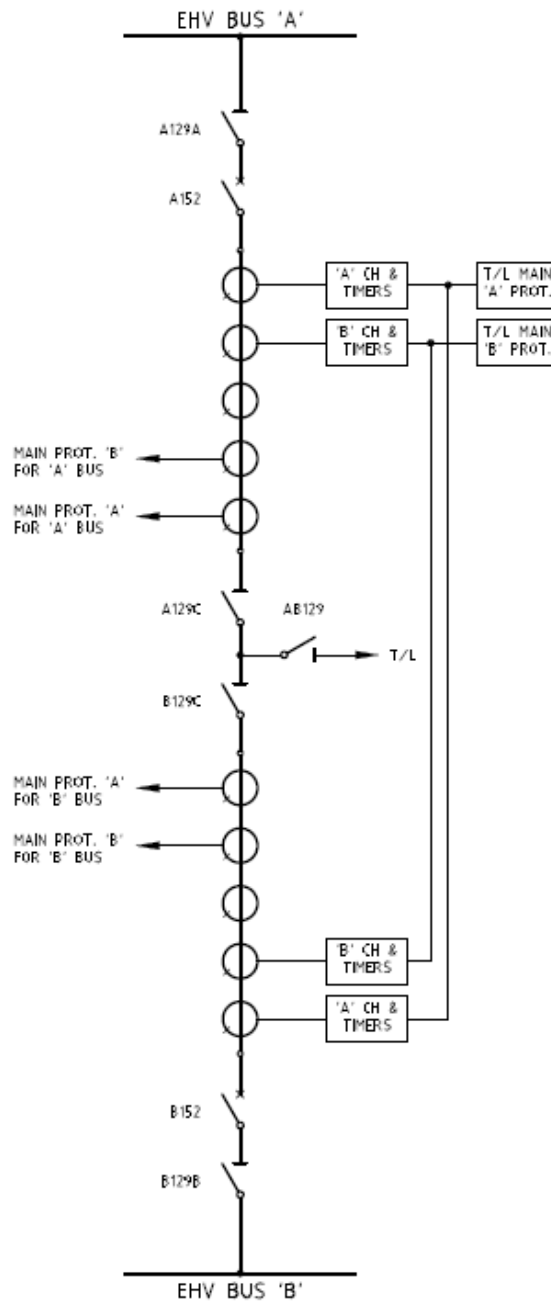

4.6 Circuit breaker and a half configuration

Figure 4 shows the typical busbar protection arrangement applied to two diameters of circuit breaker and a half configuration for network transformer and transmission line connections.

The following recommendations apply to the protection arrangement:

- (a) HIBP without a check feature may be applied as the 'A' and 'B' busbar protection schemes for each busbar associated with a circuit breaker and a half arrangement. However, at sites where IEC 61850 process and/or station bus is implemented, LIBP shall be utilised through the application of sampled values as per the design requirements specified in the TasNetworks IEC 61850 Protection and Automation Standard.

- (b) The associated circuit protections shall overlap to provide the bus protection on the respective section of the diameter. Additionally, in the event that the network transformer is removed from service and the diameter is required to remain in service, the transformer differential protection schemes shall be available to provide protection for that section of the diameter.

Figure 4 Busbar protections for circuit breaker and a half configuration

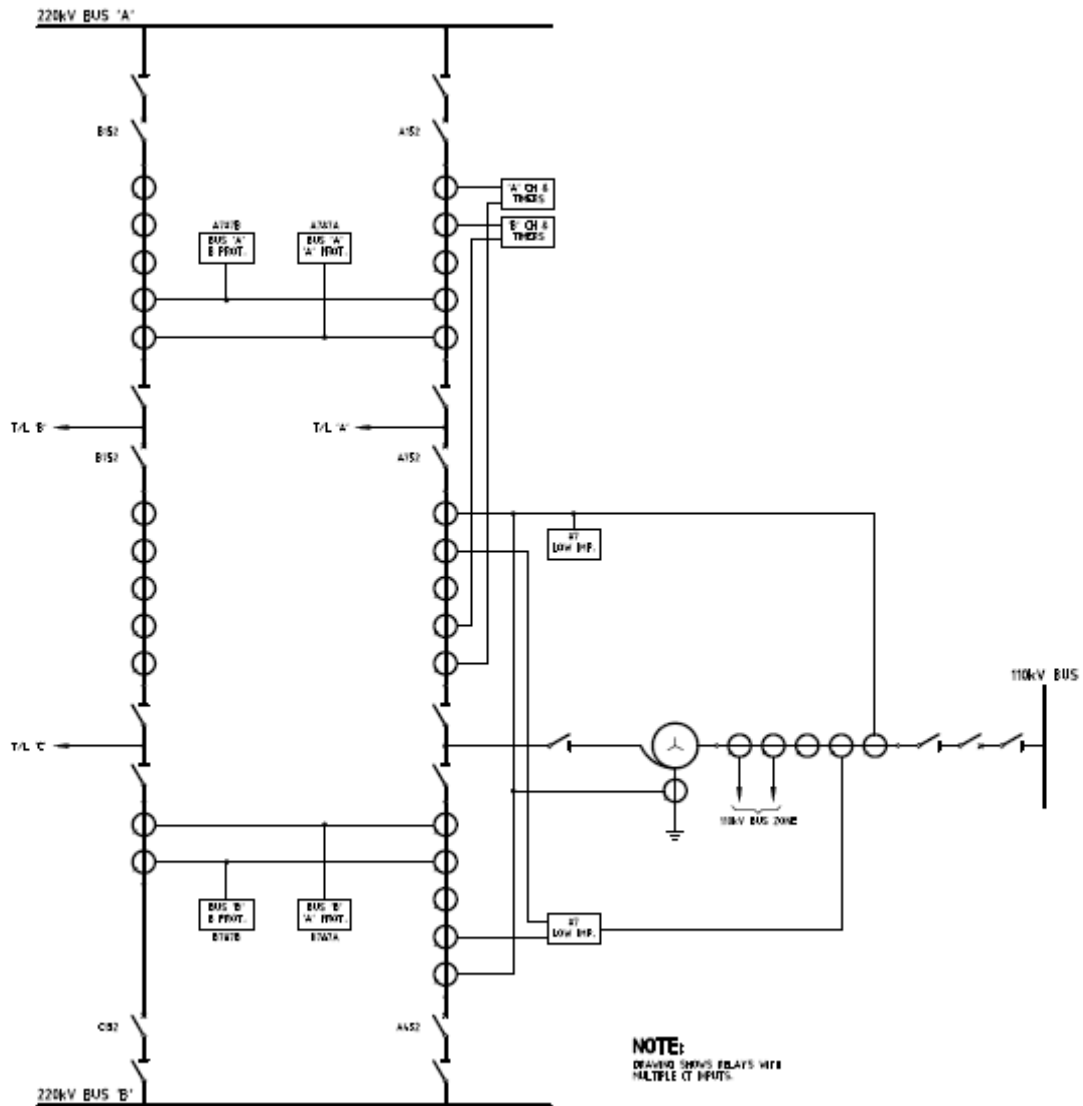

4.7 H-type configuration

The following protection design principals apply to H-type busbar configurations:

- (a) For the H-type configuration, dedicated busbar protection schemes are not warranted as the busbar protection is provided by the overlapping of the transmission line and the transformer protection schemes as shown in figures 5 and 6.

Figure 5 Busbar protections for H-type configuration with transmission line CBs

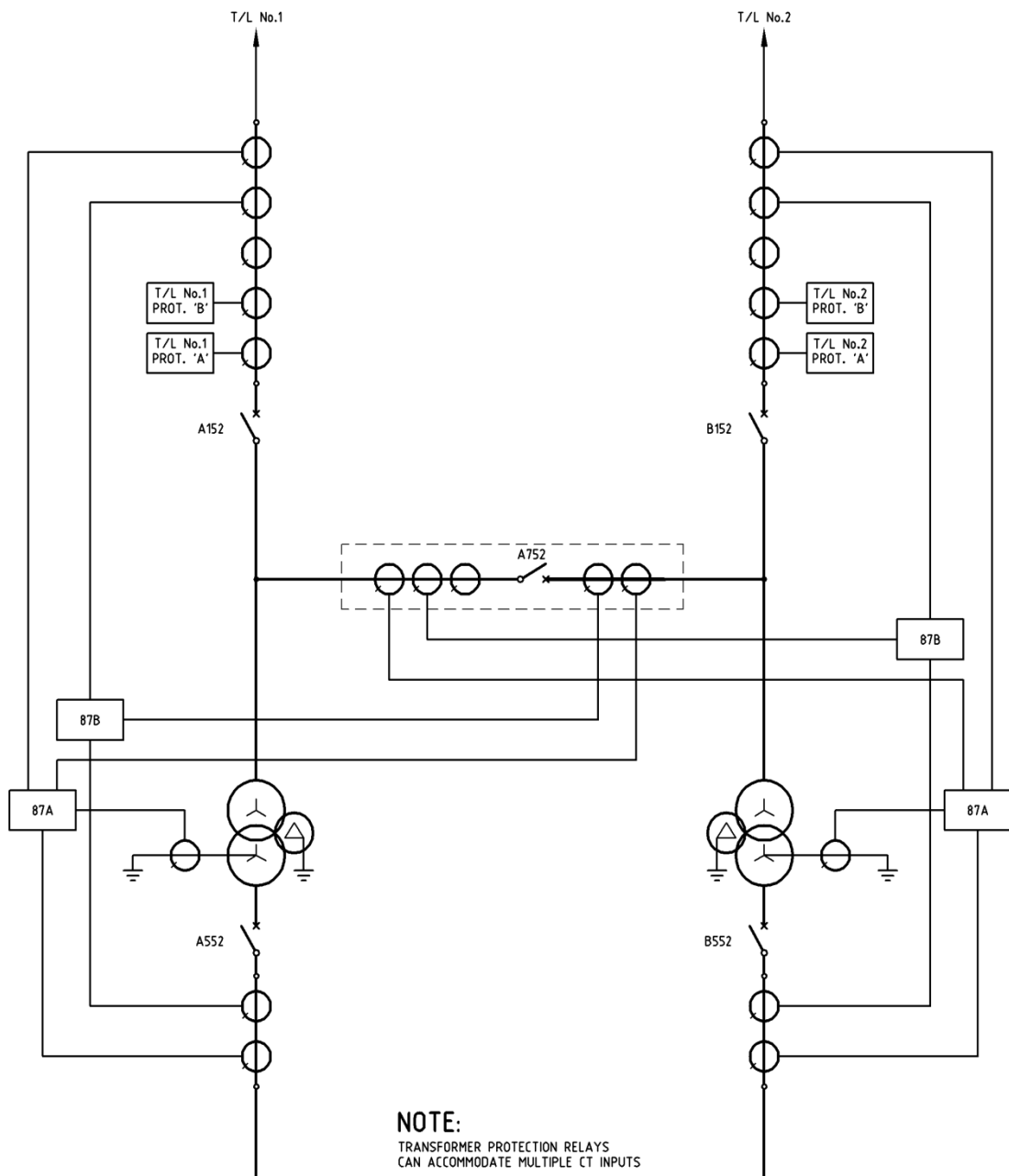
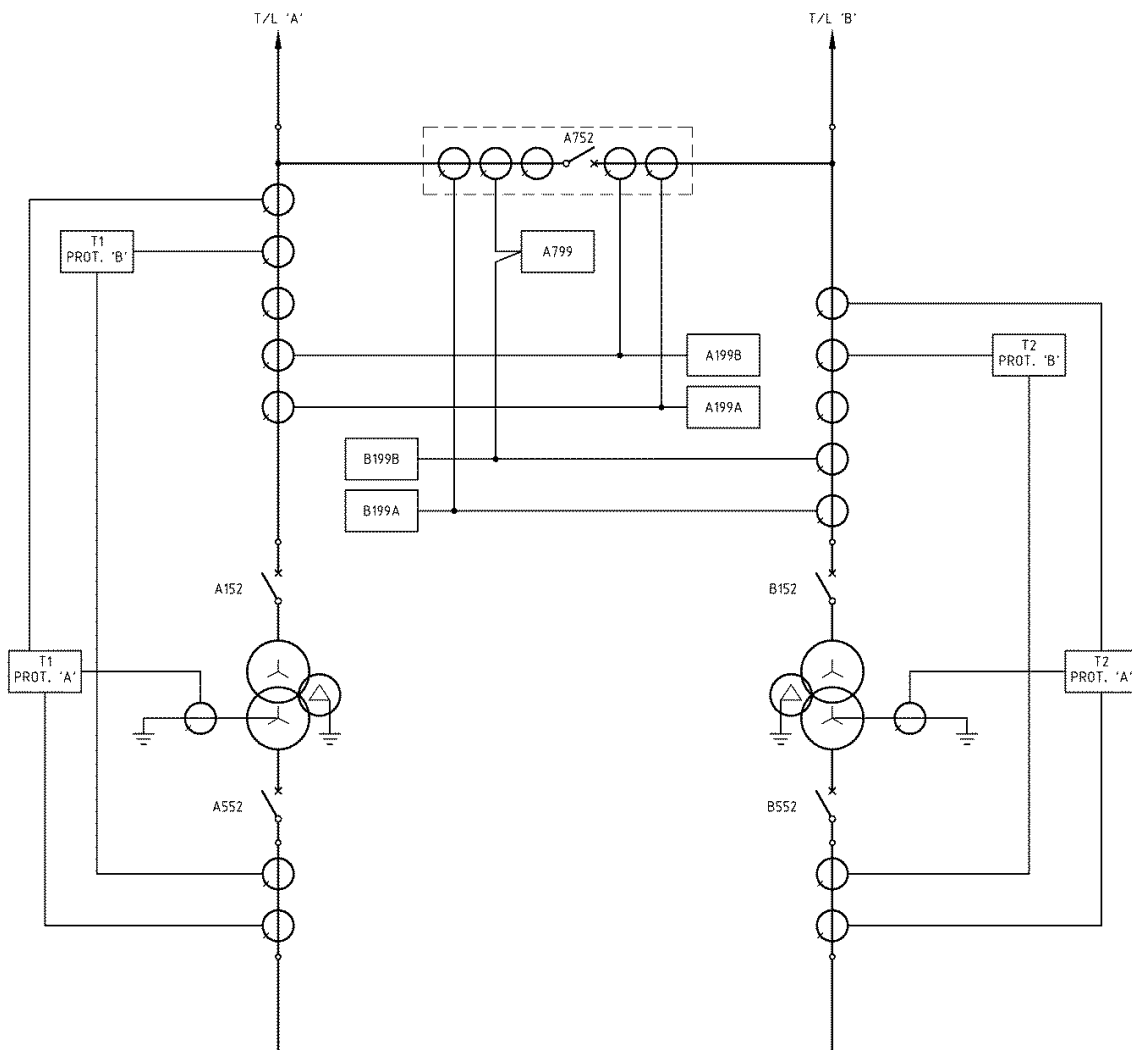

Figure 6 Busbar protections for H-type configuration with transformer CBs



5 Protection associated with EHV bus coupler

5.1 Design principles

The following design principles must be implemented:

- (a) The protection and control scheme for the EHV bus coupler shall consist of one multifunction relay located within a dedicated panel. However, for circuit breaker and a half arrangements using IEC 61850 process and/or station bus, the requirements for implementing EHV bus coupler control shall be specified in the IEC 61850 Protection and Automation Standard.
- (b) Non-directional impedance protection shall be configured in the relay which must be set to detect all faults up to 10 per cent of the length of the shortest line and will be set to operate after 200 ms time delay. This protection will only be required where busbar protection is not duplicated.
- (c) The relay shall be connected to a protection class CT and shall be able to accommodate input from one three phase bus VT and a single phase VT from the other bus for synchronising purposes.

- (d) The relay shall be configured to provide CB close permission logic, synchronising check and system synchronising.
- (e) For H-type busbar configurations, the bus coupler relay shall perform the CBF function for the bus coupler.
- (f) The relay shall provide temporary protection during substation commissioning activities, which may include distance protection or overcurrent protection.
- (g) Instantaneous earth fault protection must not be used in the temporary protection for the substation commissioning activities as this has been found to incorrectly operate during switching activities resulting in the accidental tripping of in-service CBs.

5.2 Bus coupler protection functional requirements

The bus coupler protection shall provide the following functionality:

- (a) Capable of communicating all parameters including alarms and controls to the substation SCADA system and be capable of being configured remotely.
- (b) Have a local HMI to read primary data, to establish and read setting parameters and to access self-diagnosis details.
- (c) Capable of self-supervision.
- (d) Capable of IRIG B or PTP time synchronisation.
- (e) Able to communicate to the SCADA system via DNP3.0 and IEC 61850 (GOOSE and MMS).
- (f) Provide SOE and oscillographic disturbance recording facilities with capability of remote interrogation.
- (g) Have sufficient heavy duty contacts for direct tripping of the CBs.
- (h) Be capable of trip circuit supervision.
- (i) Be capable of CBF protection.
- (j) Be capable of communicating on the SCADA network via Ethernet RJ45 or fibre connection..

6 Busbar protection settings

The setting requirements mentioned in this document are not the full requirement for settings but represent the basic setting requirements for the protection. The contractor shall supply to TasNetworks the complete list of settings including configuration details in both hard and soft copy.

Settings are to be managed in compliance with TasNetworks' device setting and configuration management procedure.

Configuration of IEC 61850 process and/or station bus shall be in accordance with TasNetworks' IEC 61850 Protection and Automation Standard.

6.1 Setting requirements for busbar differential protection

6.1.1 General information

The following general information shall be included in the protection setting report:

- (a) Name of the substation.
- (b) Busbar identification or designations.

- (c) Selected CT ratios.
- (d) Manufacturer of protection equipment.
- (e) Model number.
- (f) Firmware versions of all associated devices.
- (g) CT saturation calculation.
- (h) Maximum load current on each circuit.
- (i) Positive Sequence maximum and minimum system source impedances to busbar ($R1 + jX1$ - p.u. on 100 MVA base).
- (j) Zero Sequence maximum and minimum system source impedances to busbar ($R0 + jX0$ - p.u. on 100 MVA base).
- (k) Positive Sequence and Zero Sequence fault current contribution by all the circuits connected to the busbar for maximum and minimum source impedance conditions.

6.1.2 Setting requirement

The differential pickup shall be set to fulfil the following conditions:

- (a) Be set above the highest loaded circuit to ensure the busbar protection scheme does not operate erroneously if the CT on the highest loaded circuit fails.
- (b) Be set less than 50 per cent of the minimum three-phase or single-phase fault current on the relevant bus when the bus is supplied by a single feed.
- (c) For a LIBP scheme the bias characteristic shall be set to provide stability under CT saturation condition for a through fault based on manufacturer's recommendation.
- (d) For a HIBP scheme the stabilising resistor shall be chosen to provide stability under CT saturation condition for a maximum through fault based on manufacturer's recommendation.

TasNetworks must be notified if any of the above requirements cannot be met.

6.2 LIBP settings

The following is a minimum list of settings and information, along with supporting calculations to be provided for the LIBP:

- (a) CT ratios for each circuit.
- (b) Differential pick up setting of main and check zones.
- (c) Full bias characteristic setting.
- (d) Calculated primary operating current.
- (e) CBF pickup current and associated time delay setting.
- (f) Differential CT supervision setting.
- (g) End fault bus protection setting.
- (h) Scheme logic.

6.3 HIBP settings

The following is a minimum list of settings and information, along with supporting calculations to be provided for the HIBP:

- (a) Operating current and/or voltage setting.
- (b) Value of stabilising resistor.
- (c) Calculated primary operating current.
- (d) Differential CT supervision setting.
- (e) Type of voltage dependant resistor and associated characteristics.

7 Circuit breaker failure (CBF) protection

7.1 Design principles

The following design principles must be implemented:

- (a) Local CBF protection is to be provided for every EHV CB.
- (b) CBF protection is to be implemented in the LIBP schemes, with a retrip feature wherever possible.
- (c) CBF protection is to be implemented in the respective circuit protection relays in the case of HIBP schemes.
- (d) CBF protection is required to be duplicated in case of duplicate busbar schemes only.
- (e) CBF protection must trip all contiguous CBs capable of feeding the fault, including remote CBs where applicable.
- (f) Every protection function that sends a trip to a CB must also initiate the CBF protection.
- (g) The CBF protection should not be cascaded.
- (h) Where SPAR is to be applied, CBF current check must be phase segregated.
- (i) For circumstances where circuit breaker failure occurs for a busbar fault, the CBF protection shall be capable of identifying the faulty CB and shall, where the faulted CB is for a transmission line, send a direct inter-trip signal to the appropriate remote line end CB.

7.2 CBF protection application

The following design principles shall be followed for the application of CBF protection:

- (a) For single LIBP schemes, CBF current check elements and timers shall be configured in the LIBP scheme and single CBF shall be applied. The Main 'A' and Main 'B' circuit protections shall initiate CBF in the single LIBP scheme which will trip both trip coils of the CBs in accordance with the disconnector image of the busbars.
- (b) For duplicated LIBP schemes, CBF must also be duplicated such that the "A" protection of respective circuits initiates the CBF protection of the "A" LIBP scheme and the "B" protection of the respective circuits initiates the CBF protection of the "B" LIBP scheme. For CBF of transmission line circuits, both LIBP schemes must independently initiate direct inter-tripping of the remote end CB through the normal circuit inter-tripping arrangement, e.g. protection relay or teleprotection device.
- (c) For circuit breaker and a half arrangements, CBF protection shall be applied as follows:
 - (i) Where duplicated busbar protection schemes are applied, duplicate CBF protection shall be provided for the bus and middle CBs where possible.
 - (ii) Where HIBP protection is applied, CBF protection for the bus and middle CB shall be implemented in the Main 'A' and Main 'B' relays of the associated circuit protection scheme. If

the associated circuit Main 'A' and Main 'B' relays are not able to provide duplicate CBF protection for both CBs, single CBF protection for both CBs is sufficient.

- (iii) Where LIBP protection is applied, CBF protection for the bus CBs shall be implemented in the LIBP scheme and CBF protection for the middle CB shall be implemented in the Main 'A' and Main 'B' relays of the associated circuit protection scheme.
- (d) CBF protection for H-type busbar configurations shall be applied in the Main 'A' and Main 'B' relays of the associated circuit protection scheme. If the associated circuit Main 'A' and Main 'B' relays are not able to provide duplicate CBF protection, single CBF protection is sufficient.

7.3 CBF protection settings

The following guidelines shall be applied when setting the CBF elements:

- (a) The setting of CBF current check shall be set below 50 per cent of the minimum fault current as seen by the associated circuit protection relays.
- (b) The CBF current check should not pickup for maximum load current in the associated circuit. However, in the event that the difference between the magnitude of load current and 50 per cent of the minimum fault current is marginal, it is permissible to set the CBF current check to a value less than maximum load current.
- (c) Where possible, the CBF protection should re-trip the failed CB after 100 ms.
- (d) The CBF protection shall back-trip the remaining CBs after 200 ms to clear the affected bus.
- (e) In cases where wind farms or other forms of embedded generation sources are directly connected where fault current is likely to diminish very quickly, other methods of detection of CB status should be considered i.e. CB auxiliary contacts.

7.4 Differential current supervision

Interruptions including open or short circuited CTs can potentially disrupt the operation of the busbar protection scheme, especially during a through fault. Such condition should be detected by differential current supervision functionality. The following criteria must be applied:

- (a) The pickup setting must be above standing unbalance current under normal loading conditions.
- (b) The time delay shall be set to 5 seconds.
- (c) Differential current supervision shall block the busbar differential protection and initiate an alarm. The blocking function shall reset automatically on disappearance of the differential current.

7.5 CT circuit supervision

In cases of LIBP, it is recommended that the CT circuit supervision algorithm of each CT circuit is based on measured neutral current and derived zero sequence current.

7.6 End Fault or 'blind zone' protection

Faults occurring between the CT and the CB cannot be cleared by the busbar differential protection. For such faults to be cleared by End Fault or 'blind zone' protection, the element should be armed automatically as soon as the CB of the circuit is open. In the case of bus coupler circuits, end fault protection is a means of discriminating faults within the overlapping CTs when the bus coupler breaker is open.

For end fault protection, the following criteria must be applied:

Protection of EHV Busbars Standard

- (a) The pickup setting shall be more than maximum load of the bay and less than 50 per cent of minimum fault current at the location.
- (b) The time delay shall be 50 ms.
- (c) For line applications a direct intertrip shall be sent to the remote end to clear the fault.
- (d) Manufacturers recommendations shall be applied for a CB close command to be sent to the busbar protection to disable the End Fault protection.

Appendix 1 – Standard secondary equipment

Where possible standard equipment must be used to ensure the most efficient maintenance practices are able to be undertaken. The following table shows the standard equipment types that are currently used by TasNetworks in EHV busbar protection installations.

Note that equipment may vary for IEC 61850 process and/or station bus arrangements. These equipment variations will be stated in the IEC 61850 Protection and Automation Standard.

Device number	Manufacturer	Model	Order code	Firmware version	Standard drawings
787A (HIBP)	Siemens	7SJ82	P1J269366	TBA	
787B (HIBP)	Schneider	P143	P14331AD8M0460J	P14331AD8M0460J	
787A (LIBP)	Siemens	7SS85	As per installation requirements	TBA	
787B (LIBP)	GE	B90	As per installation requirements	TBA	
799	GE	D30	D30-N03-HLH-F8L-H6T-M6G-P6G-U6T-W6T	A09MA601.000	